

# LIGHT ENGINE USER MANUAL

MODEL:

LEI-4121DMX/WP

LEI-4241DMX/WP

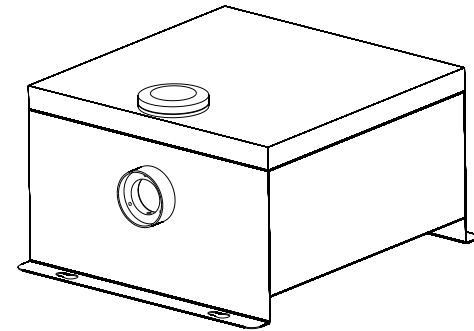

## Accessories:

- Fiber Connector .....1 PC
- Wireless Remote Controller.....1 PC (Optional)
- User Manual .....1 PC
- Signal Cable .....1 PC (for DMX machine only)



**ISO9001:2000  
CERTIFIED**

# LIGHT ENGINE USER MANUAL

Welcome to use LEI series of professional light engine. Please read the manual carefully before using the light engine. If you have any questions concerning the operation or maintenance, please contact your wholesaler.

## Safety Instruction

1. Make sure the Light Engine and Power Source have the same voltage;
2. Keep out of rain or moist area to avoid shock hazards;
3. Avoid to use at high ambient temperature ( $>40^{\circ}\text{C}$ );

## CHAPTER 1 LEI-4121DMX/WP / LEI-4241DMX/WP

### 1. Technical Data

Voltage:  110V  230V  
 Color : RGBW  
 Life of LED : 50000H  
 IP Rating IP43  
 Size:  $347 \times 287 \times 183\text{mm}^3$   
 Gross Weight: 7.0Kg  
 Standard Aperture:  $\Phi 28\text{mm} / \Phi 24\text{mm} / \Phi 20\text{mm}$  (Optional:  $\Phi 30\text{mm}$  Max)

Model: LEI-4121DMX/WP  
 Power: 50W  
 Light Source: 1-4X12W LED

Model: LEI-4241DMX/WP  
 Power: 120W  
 Light Source: 1-4X24W LED

### 2. Installation dimension of light engine (see Fig.1):

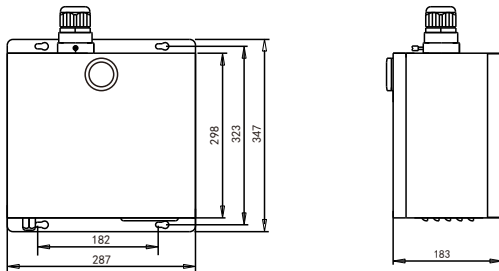

Fig. 1

### 3. Light Engine Setup

There are three control modes for LEI-Series DMX512 protocol Light Engine:

- \* DMX512 Signal Control Mode: DMX512 Signal is received from a DMX512 controller.
- \* Master/Slave Mode: One Light Engine is set as Master, while the rest light engines are set as Slave. Master sends control signal to slave so that all the machines run the program synchronously.
- \* Audio Control Mode: Light engines are controlled by sound.

### (1) DMX 512 signal control mode:

#### Address Code Setup:

Press button "UP" and "DOWN" at the same time (maybe several times) until the digital display shows "001-505", then press the button "UP" or "DOWN" to select the address code.

DMX Channels: 8 Channels

CH1:Red (256 level) CH2:Green (256 level)  
 CH3:Blue (256 level) CH4:White  
 CH5:Speed (256 level) CH6:Dimmer (256 level)  
 CH7:Strobe/Program Speed CH8:Preset Program

Notice: ① For CH8, Only "P01-P15" are available, "P016-P21" are not available;

② When CH8 is not "0", CH1~CH4 are not usable, CH7 is preset programs speed;

③ When CH8 is "0", CH1~CH6 are usable, CH7 is strobe.

### (2) Master/Slave mode: The setting of Master/Slave

STATUS	No.	MENU	DESCRIPTION OF FUNCTIONS	REMARKS
MASTER	1	p. 0 0-p. 2 1	22 preset programs(see attached list. When it displays "P.XX", press "UP/DOWN" to get into this menu)	1. Hold and press the two buttons at the same time for 3 seconds to unlock the menu for setting up.
	2	ps. 1 -ps. 2	PS. 1-PS. 2 are audio control programs (when it display "PS.X", press "UP/DOWN" to get into this menu)	2. Hold and press the button "UP", at the same time to press the button "DOWN" to switch the menu. Then release both buttons.
	3	s. 00 -s. 07	Color wheel speed setup: total 8 levels:1/2RPM, 1RPM,2RPM,3RPM,4RPM,5RPM,8RPM,12RPM	3. Press either button of "UP" or "DOWN" to choose the right parameter.
	4	d. 00 - d. 99	Adjusting of brightness: total 8 levels: d.00,d.10,d.20, d.35,d.50,d.70,d.85,d.99.(d.99.means100% brightness)	4. After 60 seconds, the data will be saved and the menu locked.
	5	r. on - r. of	r.on: Remote control is on, r.of: Remote control is off.	5. When the display is on, the dot next to the third digit will flash if there is any DMX signal coming in.
Slave DMXReceiver	6	001-505	DMX address,"001"- "505" are available	

#### Notice:

- ① If you need Master/Slaves to change color synchronously, please set all of slaves into "001";
- ② If you need Master/Slaves to chase to change color, please set slaves into "009", "017" and so on (add "8" one after another).

### (3) The connection of DMX Signal Control Mode(See Fig. 2):

Fig. 2

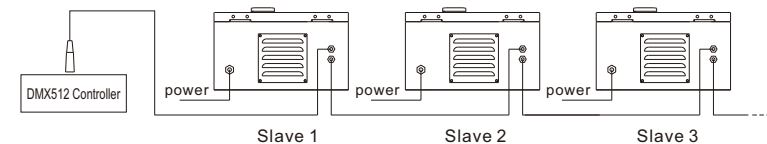

(4) The connection of Master/Slave Control Mode(See Fig. 3):

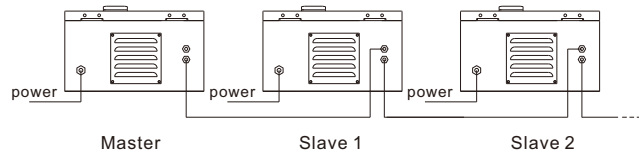

Fig. 3

(5) Signal cable and connector (See Fig.4):

Signal cable should be  $2 \times 0.5\text{mm}^2$  audio cable.

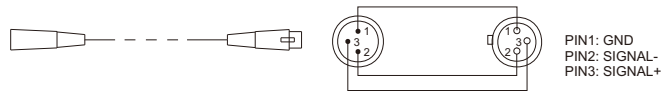

Fig.4

#### 4. Wireless remote controller (See Fig.5):

Press the two buttons "UP" / "DOWN" besides the Display at the same time. When it displays "r. on" or "r. of", press either button of "UP" / "DOWN" to show "r. on" (status of remote control). The remote function is on.

15-Key Remote Controller:

- (1) Program Selection: Press "PRO", then press the digit key on the controller, "00"-"23", to choose the desirable program, or you can use "▲", "▼" to select.
- (2) Dimming: Press the key "DIM", then press "0"-"7" to have the desirable brightness, or you can use "▲", "▼" to adjust.
- (3) Speed of the color wheel: Press the key "SP", then press "0"-"7" to adjust the speed, or you can use "▲", "▼" to adjust.

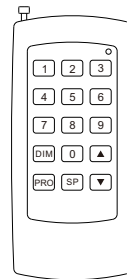

RC-15  
Wireless Remote Controller  
Fig.5

#### Notice:

- ① Address code of slave (machines) are not adjustable under remote control status.
- ② When you are selecting the program, only double-digit numbers on the controller are recognizable (e.g. 00, 01, 02...).

#### Attached Table:

Pro. No.	Function	Pro. No.	Function	Pro. No.	Function
P.00	No Light	P.08	7 colors skip	P.1 6	7 colors skip & chase
P.01	White	P.09	6 colors skip	P.1 7	6 colors skip & chase
P.02	Red	P.1 0	3 colors skip	P.1 8	3 colors skip & chase
P.03	Green	P.1 1	7 colors fade	P.1 9	7 colors fade & chase
P.04	Blue	P.1 2	6 colors fade	P.20	6 colors fade & chase
P.05	Purple	P.1 3	3 colors fade	P.21	3 colors fade & chase
P.06	Yellow	P.1 4	7 colors skip+7 colors fade	PS.1	3 colors skip & audio control
P.07	Sky-B	P.1 5	6 colors skip+6 colors fade	PS.2	3 colors skip & audio control

## Chapter 2 Installation of Fiber Optic

### 1. Connecting the fiber optic with Light Engine:

#### Solid Core fiber optic(see Fig. 1):

- (1) Cut the fiber to the specified length. The cross section should be vertical to the fiber and keep clean and smooth.
- (2) Peel off 50-100mm of the PVC jacket of the fiber optic cable (not necessary if there is no PVC jacket). Be careful not to hurt the fiber optic.
- (3) Unscrew the PG Connector and insert the fiber optic cable into the PG Connector and Fiber Connector until the end of the cable is flush with the Fiber Connector. Screw tightly the PG Connector.
- (4) Insert the finished Fiber Connector into the Fixing Flange, screw tightly the Screw.

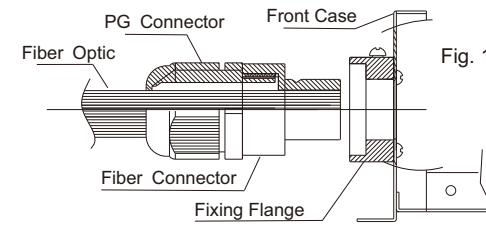

Fig. 1

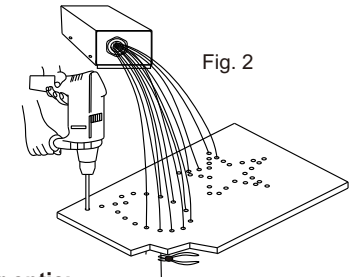

Fig. 2

### 2.Installation of the end part of the Multi-String fiber optic:

- (1) Drill holes on the installing board according to the design. Then insert the fiber optic string into holes and fix it with epoxy glue. Trim the end of the fiber string to be flush with the board or at a required length. Fasten the other end of the fiber string to a harness and insert the harness into PG Connector and Fiber Connector. Apply the hot knife to cut fiber end flush with the Fiber Connector. (see Fig.2).
- (2) Insert the finished Fiber Connector into the Fixing Flange and screw tightly the Screw.

### 3. Commonly used installation method of fiber optic cable:

- (1) Side Lighting Fiber Optic(see Fig.3).

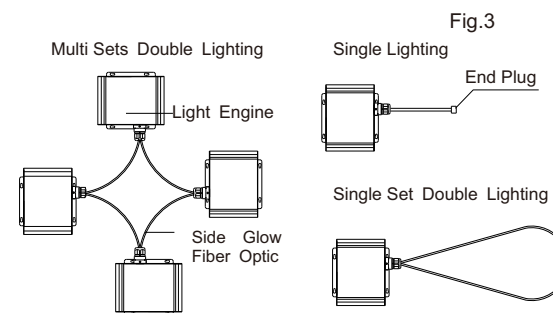

Fig.3

- (2) End Lighting Fiber Optic: (see Fig.4). Fig.4

